

1. ASSEMBLY INSTRUCTIONS

1.1 Receptacle Assembly instructions

1.1.1 Overview of exploded all parts

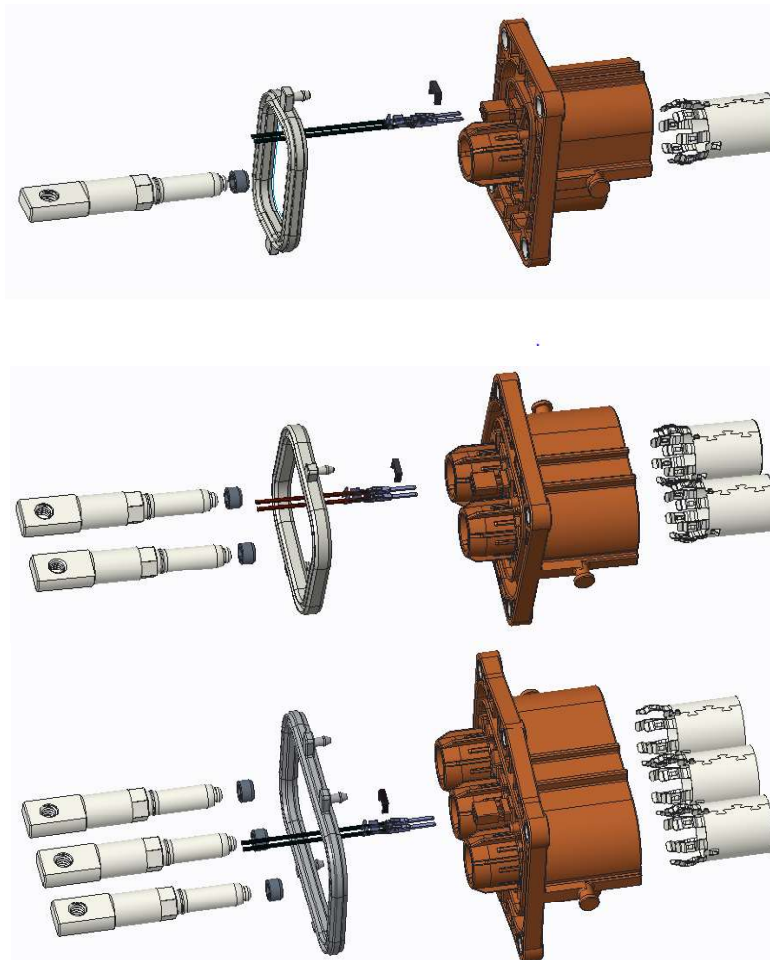

HVC800 Receptalce exploded view

1.1.2 Crimp Interlock contact

Remove the 20AWG (0.5 mm²) wire jacket 4mm.

1.1.3 Assemble the contacts into receptacle

Insert the contacts into the receptacle.

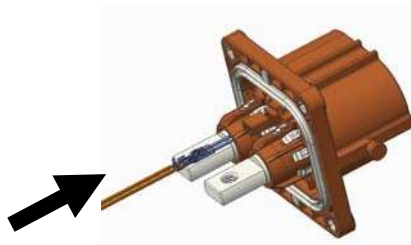

Signal line assembly diagram

1.1.3 Assemble TPA into receptacle

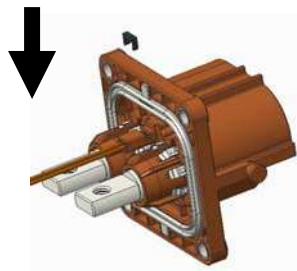
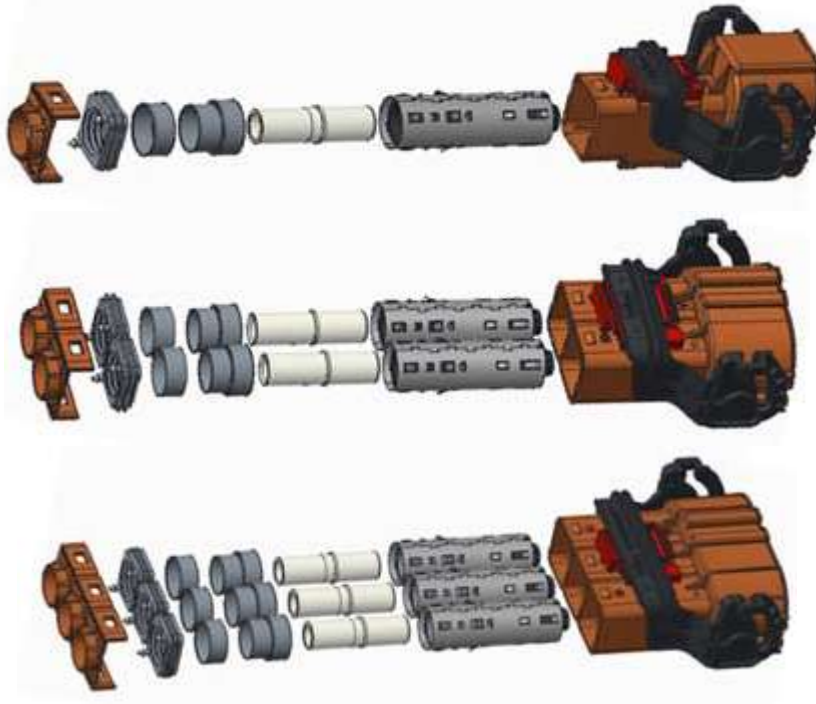

Diagram of signal terminal buckle assembly

4.2 Plug Assembly instructions

4.2.1 Overview of exploded all parts



Plug exploded view

4.2.2 Cable assembly instruction

(1) Choose the suitable cable size, assemble tail cap, waterproof ring and outer ferrule. Shown as follows:

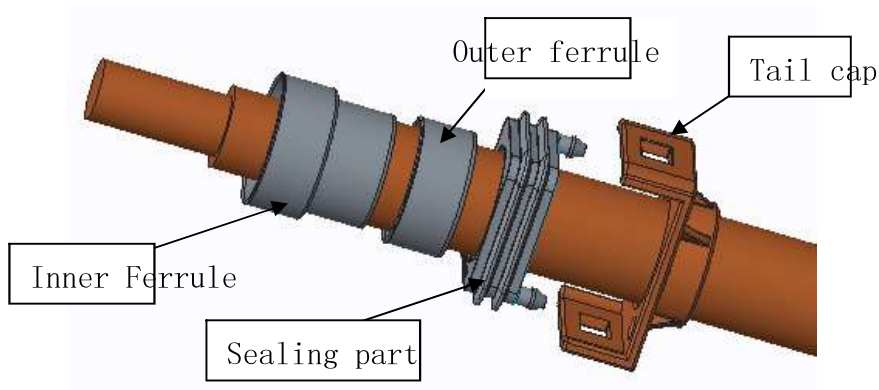

(2) Remove the outer sheath, shielding layer and inner sheath of the shielded cable of corresponding length, as shown below.

(3) 切除外护套，长度为 L1； Remove outer sheath, length L1

(4) 切除内护套，长度为 L2； Remove inner sheath, length L2

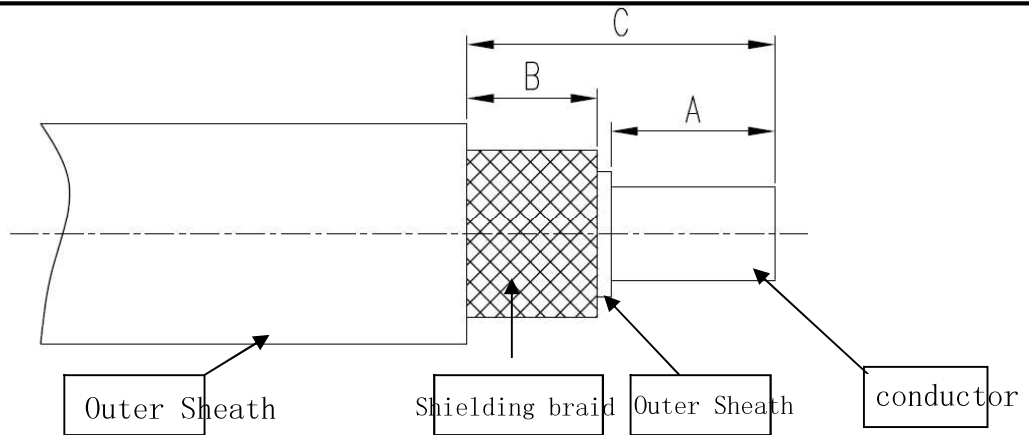

Stripping size	Length mm
Size A	21.5 ± 0.5
Size B	14 ± 0.5 (ref)
Size C	38 ± 0.5

(3)Crimp contact;

1) Section compression ratio:80%~90%;

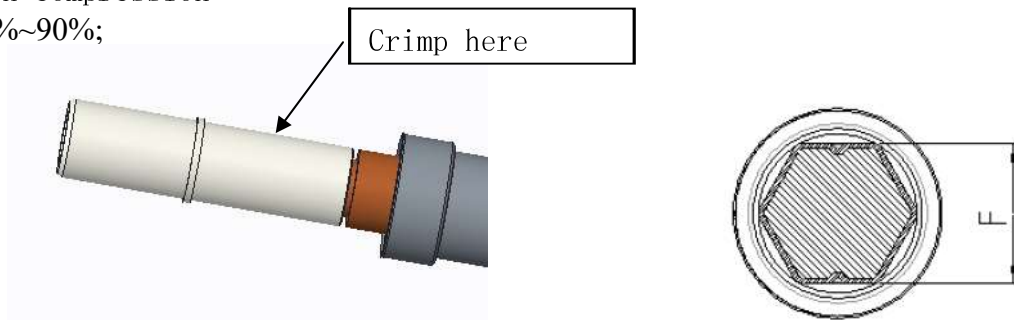

2) Crimp Height as shown below:

Cable	Height F(mm)
25mm ²	7.1 ± 0.1
35mm ²	9.3 ± 0.1
50mm ²	10.1 ± 0.1

3) Pull out force as follows:

Cable	Pull out force (Min)
25mm ²	1900N
35mm ²	2300N
50mm ²	2800N

(4) Crimp inner, outer shielding ferrule

- (a) Move the inner shield pressure pipe forward and put it on the insert sleeve;
- (b) Fold the shielding braid;
- (c) Move the inner shield pressing tube back onto the shield braid, and the step surface a in the pressing tube is about 1mm lower than the cable section B;
- (d) Then fold the shielding braid to cover the outer surface of the inner shielding cylinder;
- (e) Cover the outer shield on the shield braid;

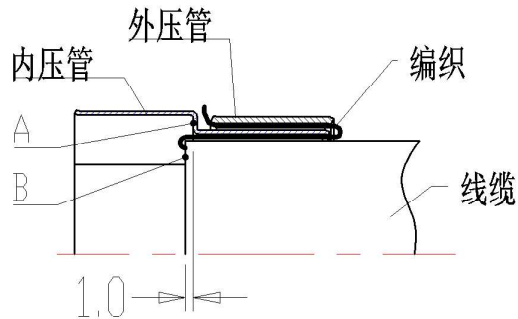

- (5) Insert the crimped contact from the bottom of the shield assembly and hear the "click" sound

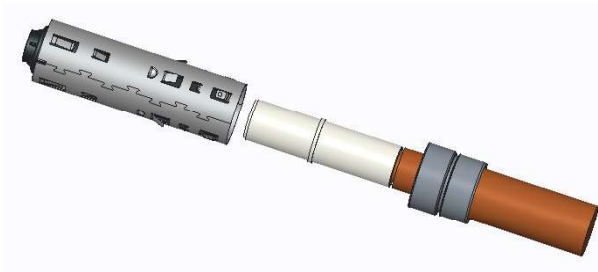

- (6) The inner ferrule also sleeved on the plug shield, as shown below:



- (7) Crimp outer shielding ferrule

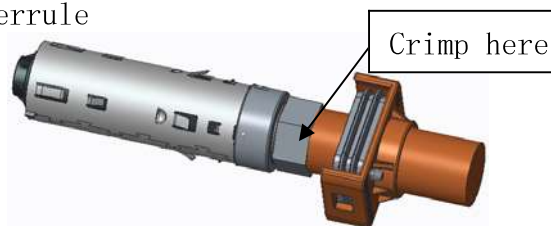

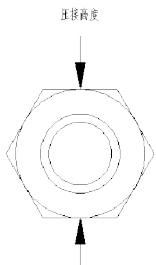

Outer shielding ferrule crimp height

Cable	P/N	Height mm
25mm ²	C120005400401	14.9 (ref)
35mm ²	C120005400402	15.8 (ref)
50mm ²	C120005400403	18.9 (ref)

注:

(1) The shielding braid can be exposed for about 1mm;

4.2.3 Assembly of finished products

1. Snap sealing part and tail cap

2 The boss on the shield corresponds to the guide groove in the plug housing; The "click" sound will be heard when the plug shield is pushed in place;

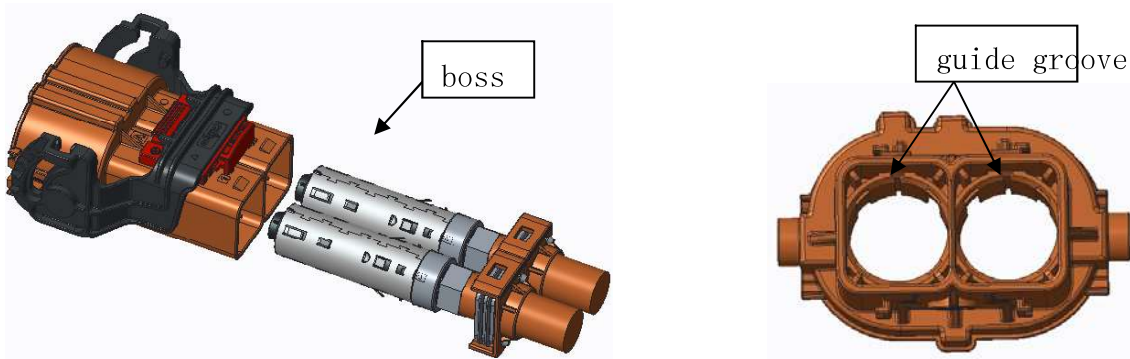

3. Assemble the cable waterproof ring and tail cap, it finish the assembly when hear "click" and see the wedge

